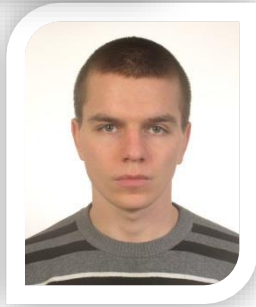

SECTION 5. Innovative technologies in science**Oleg Markovich Terentiev**

Doctor of science, Professor
Electromechanical Energy-Intensive Equipment Department
National Technical University of Ukraine
“Kyiv Polytechnic Institute”
OLTR_1@ukr.net

**Paul Anatolievich Gontar**

Post graduate student
Electromechanical Energy-Intensive Equipment Department
National Technical University of Ukraine
“Kyiv Polytechnic Institute”
gontar.co@gmail.com

IMPLEMENTATION OF THE COMBINED METHOD OF ROCK DESTRUCTION WITH EXPLOSIVE-MECHANICAL MEANS

Abstract: *An experimental installation for explosive-mechanical rocks destruction implementation was presented. Measuring devices with sensitive elements for analytical dependences testing were justified. The cutting tool of combined action was developed to provide preliminary rocks weakening by system of technological cracks with explosion energy and subsequent rocks destruction with hard-alloy cutters. Charge design provides powerful concentrated shock wave, preventing destructive impact on the cutting tool.*

Key words: *combined destruction, explosive-mechanical stressing, mathematical model, rocks destructions, technological fracturing, energy intensity of destruction*

Introduction. The share of electricity consumption by mining industry during 2012 amounted 12 billion kW·h [1, 2]. More than 10 % of the electric power developed in post soviet countries [3] are spent for destruction and crushing of rocks. Rocks' destruction when forming wells for 90 % is provided by machines with roller cone bits [4]. Thus rocks destruction rates reached the peak and further optimization is almost impossible. Therefore the combined destruction of rocks by explosive-mechanical stressing is offered. Relevance of a problem is confirmed with the resolution of the Cabinet of Ministers of Ukraine of march 1, 2010 No. 243 «About approval of the State target economic program of energy efficiency and development of the sphere of energy carriers production from renewable and alternative types of fuel for 2010 – 1015 years» [5].

The main material statement. There are difficulties for carrying out pilot studies of explosive-mechanical rocks destruction caused by lack of the necessary equipment. Standard tools aren't capable to provide research in full. Therefore one of the options for combined rocks destruction by explosive-mechanical stressing realization is developed. The figure 1 shows the installation stand with necessary sensitive elements and measuring devices.

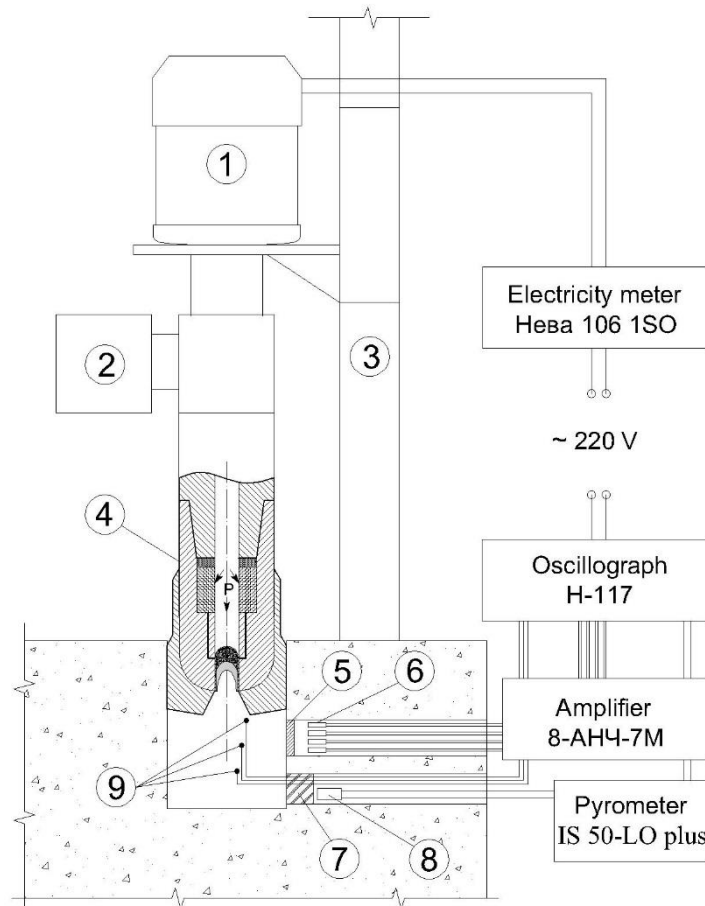

Figure 1 - The scheme of the experimental installation for combined rocks destruction by explosive-mechanical means

(1 – electric motor; 2 - swivel; 3 – framework elements; 4 –combined action cutting tool; 5 – filter; 6 – strain gages; 7 – organic glass; 8 – pyrometer lens.)

As power supply the three-phase asynchronous AIR-90-L2 electric motor (Ukraine) is chosen. Works as from industrial (380 V), and from household (220 V) alternating current mains. Engine capacity (3 kW), rotation frequency (3000 rpm), efficiency - 82,5 %. The motor mass of 20,6 kg provides vertical effort ≈ 206 N which via cutting tool transferred to a bottomhole.

For explosive-mechanical rocks destruction the cutting tool of combined action (figure 2) is developed. The design provides preliminary rocks weakening by system of technological cracks caused by explosion energy influence.

The cutter is attached to a shaft 1 by means of the castle type conic carving. The conic carving provides tightness and reliability of the fastening. Via the blowing-off channel 2 air is forced and there is delivery of the explosive charge 6 to a bottomhole. The charge is fixed by the ring 7, blocking an air stream. As a result the internal pressure P increases. As the pressure achieves minimum admissible value piezoelements 4 are deformed, forming an electric discharge which through the electrodes 5 initiates explosion of the charge 5. Explosion provides technological fracturing formation with temporary advancing. Then hard-alloy cutters 8 destroy rocks weakened by set of technological and natural fractures. Rubber laying 3 is the buffer between the cutting tool and the shaft 1.

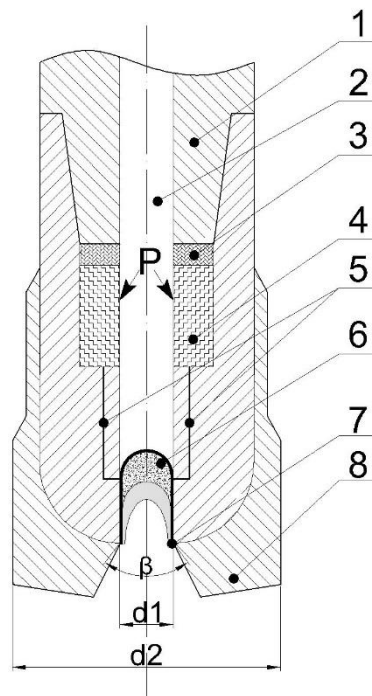

Figure 2 – The combined action cutting tool design.

The phenomenon of shock waves gradient acceleration [6] is known. The principle of such charges action consists in condensed explosive and buffer substance (gas) cascade initiation. Hemispherical charges application of cascade type allowed to increase shock wave pressure up to 20 GPa [6], and speed up to 50 km/s [6]. For combined rocks destruction implementation it is necessary to place a charge in limited space. Charge design has to provide powerful concentrated shock wave, preventing destructive impact on the cutting tool. The top part of the charge is filled with condensed explosive, the lower part – flammable gas methane (CH_4). Density of majority condensed explosives is 1000... 2000 kg/m^3 [7], and during the detonation it increases almost by 1,5 times [8]. Density of methane (CH_4) is 0,71 kg/m^3 [9] that provides area of the lowered pressure under condensed explosive. Respectively there is a gradient of pressures when consecutive impact of explosive and flammable gas layers is going on. The shock wave with an elevated pressure goes to gas with lowered pressure. Subsequent detonation of gas strengthens the shock wave, and ellipsoidal facing concentrates energy of explosion on a bottomhole.

The charge's cone-shaped framework (figure 3) is made of plastic with dome-shaped top 1. There is ellipsoidal facing VII to provide shock wave concentrated stream. Condensed explosive IV and flammable gas VI (CH_4) are sources of the shock wave. Between them there is a metallized maylar film V. Using of cascade type charges provides condensed explosives economy with explosion energy efficiency preservation. Condensed explosive IV energy is increased by gas VI which are separated by the diaphragm V. There are metal plates II placed in dome-shaped part of the framework III to transfer electric discharges to the detonator I.

The light-beam oscillograph H-117 (USSR) is applied for measurement results fixing. The oscillograph has a pass-band of (0... 15) kHz. It is capable to simultaneous register up to 12 processes on electrical and non electrical quantities changing in time. Measurement results recorded on ultraviolet photographic paper, which doesn't need chemical manifestation. The record maximum speed on photographic paper is 180 m/s, that meets requirements of high-speed processes measurements, such as explosion. Error $\pm 3... 5\%$ and sensitivity 2... 10 mV/div of the device allow to carry out exact measurements.

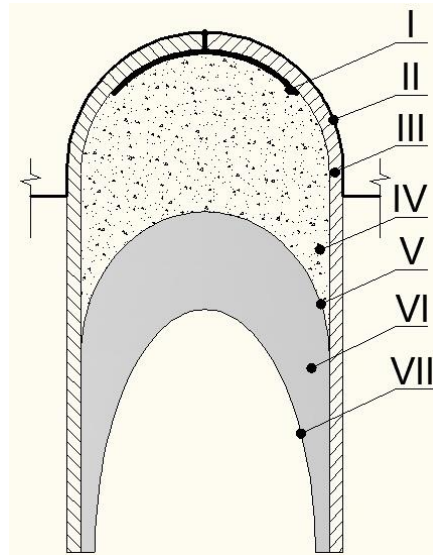

Figure 3 – Charge design.

Hydrocarbon (carbonic) resistors (51 Ohm, 0,125 W) are applied to measure the shock wave pressure value. They allow to measure up to 14 GPa [10] pressure. There is a filter (attenuator) 5 (figure 2.1) 6,5 mm thick between resistors and shock wave. The filter has to prevent destruction of resistors, because shock wave pressure can be reached 10 GPa [11].

Resistors are connected among themselves by Wheatstone bridge [12]. R1 and R3 resistors have constant resistance, the R2 resistor is adjusted to bridge balance establishment. The Rx resistor is under the influence of shock wave pressure. When the bridge is balanced, it means that current on all resistors identical and voltage between C and B equals to zero. When the shock wave impacts the Rx resistor, its resistance changes and respectively between points C and B voltage is formed. Thus pressure of the shock wave is an input signal and tension - output. Then the output signal arrives to the oscillograph for graphic definition of the pressure value changing over time.

Temperature measurement is carried out by an infrared pyrometer IS 50-LO plus (Germany). The device provides contactless measurement of temperatures in the range of (250... 3500) K. Advantages are: operation time < 1 ms, minimum diameter of measurement area is 0,45 mm, an error at $T > 1500$ K: 0,5 %, maximum distance from object of measurement is 4,5 m. Sensitive element is the lens 8 (figure 1) which is protected by 70 mm thick organic glass 7 (figure 1). For graphic display of the detonation products temperature changing in time, the pyrometer is connected to the oscillograph.

An economical method [13] of shock wave trajectory definition with antennas usage is known. The negative electric potential is formed when the shock wave passing through antennas [14]. This method is applied to current research to measure how shock wave speed changes over time. Antennas are the coaxial cable with naked central vein (a sensitive element). The system of antennas is placed on a way of the shock wave distribution. The opposite ends of cables are connected to the oscillograph through the amplifier (figure 1).

The electric power consumption is fixed by the meter Neva 106 1SO (Russian Federation) (figure 1). Can be work in single-phase and three-phase chains of alternating current. Accuracy of the electricity meter is 1,0 % that provides correct measurements.

Conclusion

1. The stand of experimental installation for explosive-mechanical rocks destruction implementation is presented. The design of the cutting tool and cascade type explosive charge is developed.

2. Measuring devices with sensitive elements for analytical dependences testing are picked up and proved: electric power consumption for rocks destruction from: shock wave pressure $e=f(P)$; detonation products temperature of $e=f(T)$; shock wave speed $e=f(v)$.

References:

1. Проблеми розвитку енергетики. [Електронний ресурс]. – Режим доступу: <http://archive.nbu.gov.ua/portal/All/herald/2001-03/9.htm>
2. Структура споживання електричної енергії по Україні. [Електронний ресурс] / Державне підприємство НЕК «Укренерго» – Режим доступу: http://www.ukrenergo.energy.gov.ua/ukrenergo/control/uk/publish/article?art_id=129077&cat_id=35380
3. Тангаев И. А. Энергоемкость процессов добычи и переработки полезных ископаемых [Текст] / И. А. Тангаев. – М.: Недра, 1986. - 231 с.
4. Решетняк С. П. Буровое и горнотранспортное оборудование железнорудных карьеров России и стран СНГ [Текст] / С. П. Решетняк, А. В. Самолазов, Н. И. Паладеева // Горная Промышленность – 2009. - №5 - 18 с.
5. Постанова Кабінету Міністрів України від 1 березня 2010 р. № 243. [Електронний ресурс]. – Режим доступу: <http://zakon1.rada.gov.ua/laws/show/243-2010-%D0%BF>
6. Асиновский Э. Л., Лебедев Е. Ф. Взрывные генераторы мощных импульсов электрического тока [Текст] / Э. Л. Асиновский, Е. Ф. Лебедев / Под ред. В. Е. Фортон. – М.: Наука, 2002. – 399 с. ISBN 5-02-002602-6.
7. Иванов Б. А. Безопасность работы с жидким кислородом [Текст] / Б. А. Иванов, А. С. Розовский. – М.: Химия, 1981. – 224 с.
8. Сысоев Н. Н. Ударные волны в газах и конденсированных средах [Текст] / Н. Н. Сысоев, Ф. В. Шугаев. – М.: Изд-во МГУ, 1987. – 133 с.
9. Плотность метана. [Электронный ресурс] / Википедия. Свободная энциклопедия. – Режим доступа: <http://ru.wikipedia.org/wiki/%D0%9C%D0%B5%D1%82%D0%B0%D0%BD> – 05.03.2014 г. – Загл. с экрана.
10. Temperature and pressure measurements comparison of the aluminized emulsion explosives detonation front and products expansion. [Electronic source] / © ResearchGate.Net. – Access mode: http://www.researchgate.net/publication/239533459_TEMPERATURE_AND_PRESSURE_MEASUREMENTS_COMPARISON_OF_THE_ALUMINIZED_EMULSION_EXPLOSIVES_DETONATION_FRONT_AND_PRODUCTS_EXPANSION.
11. Баум Р. А., Физика взрыва [Текст] / Р. А. Баум, К. П. Станюкевич. - М.: Наука, 1959. - 800 с.
12. Измерительный мост. [Электронный ресурс] / Википедия. Свободная энциклопедия. – Режим доступа: http://ru.wikipedia.org/wiki/%D0%98%D0%B7%D0%BC%D0%B5%D1%80%D0%B8%D1%82%D0%B5%D0%BB%D1%8C%D0%BD%D1%8B%D0%B9_%D0%BC%D0%BE%D1%81%D1%82 – 05.03.2014 г. – Загл. с экрана.
13. Гельфанд Б. Е. Регистрация положения фронта ударной волны в воздухе [Текст] / Б. Е. Гельфанд, И. М. Воскобойников, С. В. Хомик. – «Физика горения и взрыва» Т.40. - №6. – 2004. – С. 138 – 140.
14. Богомолов В. М. Электромагнитные явления, сопровождающие детонацию зарядов мощных ВВ [Текст] / В. М. Богомолов, И. М. Воскобойников, А. Я. Апин // Взрывное дело. - М.: Недра, 1970. - № 68/25. - С. 197–202.